



5MP SMART DUAL ILLUMINATION TURRET NETWORK CAMERA

INTIPCT528DL2



KEY FEATURES

- 1/3" progressive scan CMOS
- 2.8mm fixed lens
- Max resolution 2560×1920@20fps
- DWDR, 3D DNR, HLC, BLC, Defog
- Support intrusion and line crossing based on human detection
- Built-in IR LED and white lights, IR distance up to 20m, white light distance up to 20m
- 12V DC/PoE power supply
- IP66



Microphone



Human
Detection



PoE



IP66



LED Light



Easy
Mount

FIRE • SECURITY • INTERCOMS



SPECIFICATIONS

Model	INTIPCT528DL2	
Camera	Image Sensor	1/3" Progressive Scan CMOS
	Electronic Shutter	Auto/Manual, 1/5 - 1/20,000s
	Min. illumination	Color: 0.1 Lux @ (F1.6,AGC ON), 0 Lux with illumination on
	S/N Ratio	55 dB
	Day & Night	IR cut filter
	Wide Dynamic Range	DWDR
	Illumination Distance	IR distance up to 20m (66.61 ft) White light distance up to 20m (66.61 ft)
	Illumination On/Off Control	Auto/Manual
	Pan/Tilt/Rotation Range	Pan: 0° - 360°, Tilt: 0° - 75°, Rotation: 0° - 360°
	Lens	Lens Type
Iris		Fixed Iris
Focal Length		2.8 mm
F Number		F1.6
Angle of View		H: 93.2°, V: 50.2°
Video	Max. Resolution	2560(H)×1920(V)
	Streaming Capability	2 Streams
	Stream/Frame Rate	Main Stream: 2560×1920, 2560×1440, 2304×1296, 1920×1080, 1280×720, 704×576 @ 20fps Sub Stream: 640×360 @ 20fps
	Bit Rate Control	CBR/VBR
	Bit Rate	Main Stream: 512kbps - 6144kbps Sub Stream: 128kbps - 1536kbps
Image	Image Adjustment	Brightness/Sharpness/Contrast/Saturation
	White Balance	Auto/Manual
	Mirror	Support
	Exposure Mode	Auto/Manual
	Day/Night Setting	Auto, Day, Night, Timing
	Noise Reduction	2D/3D DNR
	Image Enhancement	WDR, HLC, BLC, Defog
	Privacy Masking	Support
Audio	Audio Compression	G.711 (64kbps)
Alarm Event	Motion Detection	Support
	Smart Function	Support intrusion and line crossing based on human detection
Network	Protocols	IPv4, RTSP/RTP/RTCP, TCP/UDP,DHCP, DNS, DDNS, UPNP, ICMP, IGMP, NTP, SMTP, 802.1x, SNMP, HTTP/HTTPS, PPPOE
	Front End Access Protocol	ONVIF, SDK
	Max. User Access	4 Users
	Web Viewer	<IE11, Chrome, Firefox, Microsoft Edge
	Management Software	SunView
Interface	Network Interface	1 Ethernet (10/100 Base-T) RJ-45 Connector
	Microphone	Support
	Reset Button	Support
	SD Card Slot	Built-in, up to 256GB



Model		INTIPCT528DL2
General	Power Supply	DC12V (-15%~+25%)/POE (IEEE 802.3af)
	Power Consumption	Max 5 W
	Operating Temperature	-25°C ~ 55°C (-13°F ~ 131°F)
	Operating Humidity	Less than 90% RH
	Ingress Protection	IP66
	Certifications	CE/FCC
	Casing	Metal + Plastic
	Dimensions	Φ111 × 95mm
	Net Weight	0.35 kg (0.77 lb)

DIMENSIONS

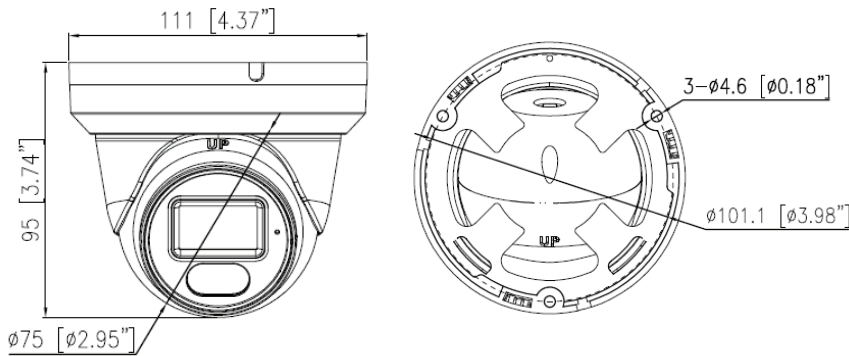

ACCESSORY



Pendant Cap
SN-CBK202A



Wall Bracket
SN-CBK501

FIRE • SECURITY • INTERCOMS